

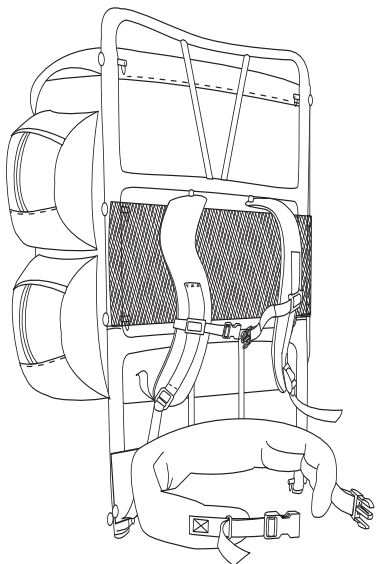

Trail Series

-TIOGA, TREKKER, YUKON &
JR. TIOGA-

EXTERNAL SUSPENSION INSTRUCTIONS



TREKKER & JR. TIOGA

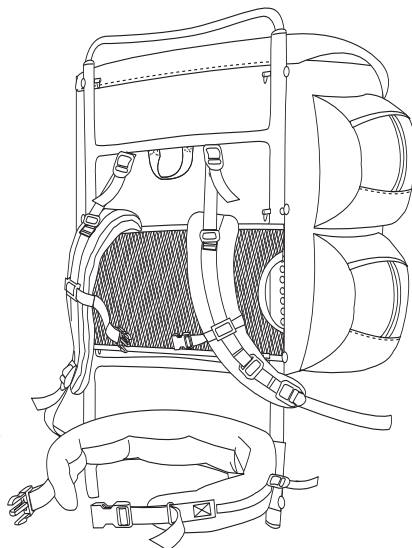

TIOGA & YUKON

INSTRUCTION INDEX

Safety Warnings	p. 2-3
Care & Cleaning	p. 3
Suspension Features	p. 4
Custom Fitting your Pack	p. 5-9
Frame Shaping	p. 9-10
Packing Hints	p. 11
Kelty Warranty	p. 12

Save these instructions for future reference.



SAFETY INFORMATION

-IMPORTANT-

- **Read, and follow, all instructions before using this backpack!**
- **Failure to follow these warnings could result in a potentially hazardous situation which, if not avoided could cause rapid fatigue, death, serious injury or permanent disability to you or others.**

! WARNING indicates a potentially hazardous situation which, if not avoided, could result in death or serious injury.

! CAUTION indicates a potentially hazardous situation which, if not avoided, could result in property damage.

! WARNING

THIS BACKPACK MAY AFFECT YOUR COORDINATION AND BALANCE

- Before use, DO familiarize yourself with the added weight of the pack and contents.
- DO use a spotter to assist when hoisting pack onto shoulders.
- When strapping items such as skis to pack, be aware that they can catch on overhead obstructions causing you to lose your balance and fall.
- DO NOT overload pack, don't carry more weight than you can manage.

! WARNING

PROTECT YOURSELF

- DO NOT place backpack near a campfire, stove or any open flame.
- Only carry liquid fuel in containers approved for such use and make sure they are tightly sealed before placing in a pack.

! CAUTION

DO NOT USE A DAMAGED BACKPACK

- DO check the condition of the backpack before each use.
- DO check to assure all buckles snaps, straps, and adjustments are secure before each use.
- DO NOT use pack if the frame, fabric, straps or buckles are damaged.
- DO NOT use pack if pack is damaged in any way.
- DO NOT leave (store) a pack in direct sunlight. Ultra-violet light will cause materials to weaken and fade.
- For assistance in repairing your pack or answering any questions, call Kelty Customer support staff; toll free at 866-349-7225 (866-FIX-PACK).

CARE AND CLEANING

1. Brush off loose dirt with a dry brush.
2. As needed, wipe out the inside with a damp sponge and mild soap.
3. Rinse only, if possible. Use cold water and a sponge or rinse in a tub without soap.
4. Machine wash in front-loading unit (DO NOT use machine with agitator, agitator could cause damage not covered under warranty) with cold water and mild soap (Ivory Flakes, Woolite, Sport Wash, Etc.) Not detergents.
5. DO NOT soak in soapy water, it may cause damage to the coated fabric.
6. Rinse thoroughly to eliminate soap residue.
7. DO NOT use a dryer, air dry only.
8. Always store in a cool, dry area.

ZIPPER CARE

1. Keep loose threads trimmed.
2. Keep free from dirt.
3. Spray periodically with a non-greasy, non-staining silicone spray designed for fabrics.
4. To prevent salt water corrosion on zipper pulls, make sure you rinse with clear water after exposure.

1. SUSPENSION FEATURES

The Tioga, Trekker, Yukon and Jr. Tioga suspensions features:

THE H-FRAME is the classic workhorse frame. This frame moves the waistbelt down, preventing towering loads and providing greater load transfer to the hips than other frames. The H-Frame tends to fit people with wider torsos.

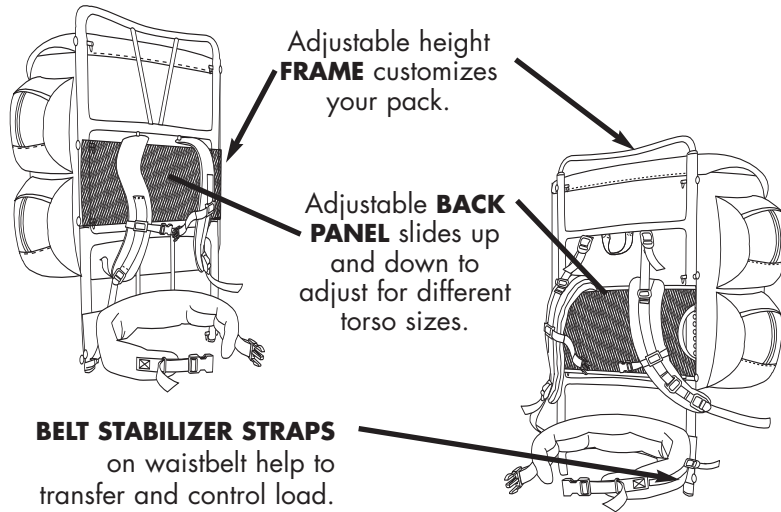

2. FITTING YOUR PACK

Follow these steps **IN SEQUENCE** to achieve the best fit every time you use your pack. Refer to the figure above to identify pack parts.

Before starting, loosen all load-lifter and belt stabilizer straps.

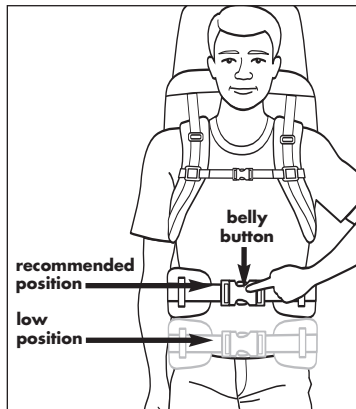

Figure 2A

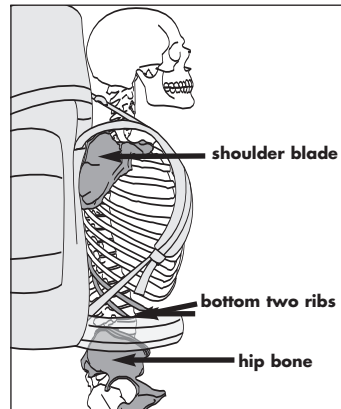

Figure 2B

A. FIRST weight the pack with at least 25 lb. (35 lb. is ideal).

B. NEXT put the pack on and tighten the waistbelt. Make sure you place the waistbelt in the proper location (Figures 2A & 2B).

It is recommended to wear the belt on hip bones, just under the rib cage. If you still prefer to wear the belt low, add one to two inches to your torso length measurement. Figure 2A shows both the preferred placement of the waistbelt and an example of a belt worn low. The low position is not recommended. Once positioned correctly, tighten the belt to prevent it from sliding. (A good rule of thumb is to have the belt buckle approximately over your belly button.)

Benefits of wearing the belt high on the waist:

- Proper loading of the skeletal frame, further supported by the two strongest muscle groups in the body: the quadriceps & gluteals.
- Blood flow & nerves route across the front of the hips; wearing the belt too low can restrict blood flow causing muscle fatigue, nerve pinching and possible numbness.

C. Once the waistbelt is in the correct position, tighten the shoulder straps. To tighten shoulder straps pull the webbing at the lower ends of the shoulder strap down & back. The top of the load lifter strap should be 3-4" inches above the top of your shoulder (Figure 2C). (Put a little more load on your shoulders than you want to end up with.) During this operation the load-lifter straps should be kept loose.

With the waistbelt positioned correctly and the shoulder straps as shown below, you have achieved a perfect fit.



Figure 2C

If you do not have the correct shoulder strap position, you will need to adjust the torso length as directed in the following section.

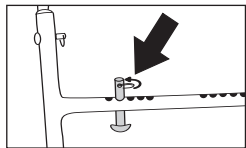

Figure 2D

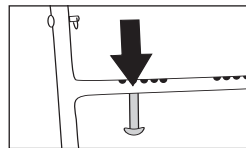

Figure 2E

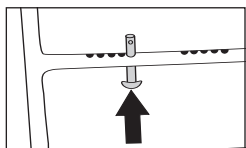

Figure 2F

If the shoulder straps are pinching your neck or shoulders or feel too wide, you need to adjust the clevis pins that attach to straps to the frame.

- I. Remove split ring from clevis pin (Figure 2D).
- II. Slide clevis pin out of frame (Figure 2E).
- III. Insert clevis pin into desired hole (Figure 2F) and replace split ring.
- IV. Repeat steps I-III for opposite side.

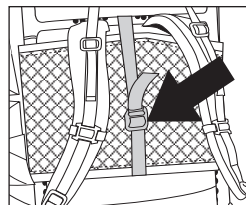

Figure 2G

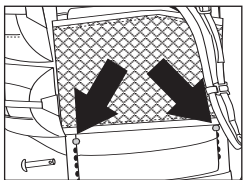

Figure 2H

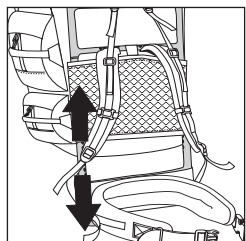

Figure 2I

- a. Reach behind the mesh panel from the bottom and generously loosen the black vertical strap behind the backpanel (Figure 2G).
- b. Find the chrome buttons and the clevis pins on the frame under the backpanel. Remove the clevis pins on either side of the frame.
- c. Push in the two chrome buttons (Figure 2H) while sliding the frame up or down (Figure 2I).
- d. Replace the clevis pins in holes just underneath chrome buttons and tighten the vertical strap.

SHOULDER STRAP ADJUSTMENT

TORSO LENGTH ADJUSTMENT

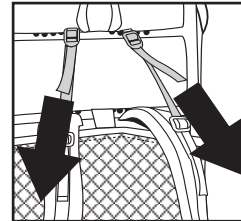

Figure 2J

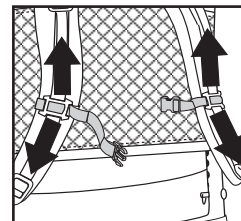

Figure 2K

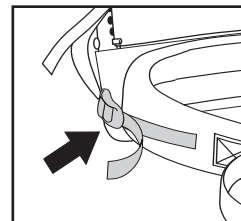

Figure 2L

D. Snug the load-lifter straps (Figure 2J), if applicable. This lifts the shoulder straps (and the pack's weight) off the top of your shoulders. Don't allow the load-lifters to pull the shoulder straps more than 1/2" off your shoulder, or it will cause pressure points.

E. OPTIONAL- Position the sternum strap (Figure 2K) on your chest, and pull it snug. The sternum strap should cross your chest high, just below your clavicle, so it doesn't interfere with your breathing. Some people find it more comfortable not to use the sternum strap when breathing hard—especially at altitude.

F. OPTIONAL- Pull the belt stabilizers just snug (Figure 2L), if applicable. If overtightening them feels good, you might need to bend more curve into the frame in the lumbar region. Overtightening causes gaps between you and the belt. Belt stabilizers are best left loose for the first 15-30 minutes of hiking.)

3. HOLD-OPEN BAR

Each external frame pack comes with a hold-open bar. Follow the steps to install it.

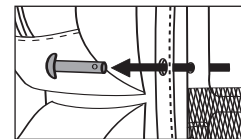

Figure 3A

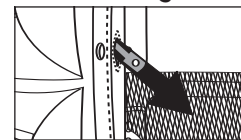

Figure 3B

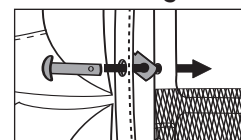

Figure 3C

- A. Remove split ring and clevis pin on the frame just above the mesh backpanel (Figure 3A).
- B. Slide foot of hold-open bar, located inside the packbag, through the button hole in the back of the packbag (Figure 3B).
- C. Thread the clevis pins back into position, make sure to go through the packbag, the foot of the hold-open bar and the frame (Figure 3C), then replace the split ring.
- D. Repeat steps A-C on opposite side of the pack.

4. PACKING HINTS

Loading the pack greatly affects your comfort—follow the guidelines below for optimum comfort.

HEAVY ITEMS

- Water
- Stove
- Fuel
- Food
- Tent poles

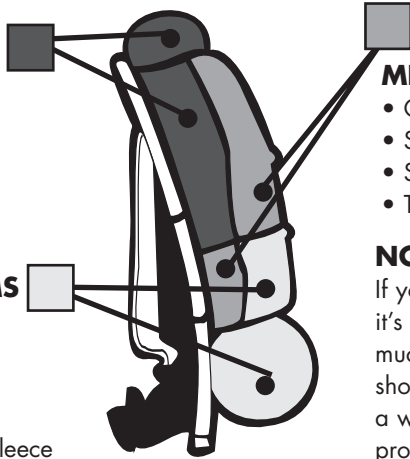

MEDIUM ITEMS

- Cooking utensils
- Some clothing
- Some foods
- Tent body and fly

NOTE:

If your pack feels like it's leaning away too much from your shoulders, you have a weight distribution problem.

LIGHTEST ITEMS

- Sleeping bag
- Pad
- Rain, wind gear
- Bivy sack
- Bulky clothing/ fleece

Hints to keep you comfortable when out on the trail:

- When balance is crucial for off-trail travel, climbing or skiing, pack heavy items centered and close to the back.
- The sleeping bag should always go in or on the bottom of the pack.
- Pack clothing and other light gear around heavy items (ie. a stove or climbing gear) in order to keep them from shifting.
- Items you will need during the day should be packed in the top of the main compartment, the top pocket, or side pockets.
- Foam pads and odd-sized equipment (such as long tent poles) can be carried on the outside of the pack. Use the appropriate accessory patches, ice axe loop, or ski slots for these items.
- Do not put heavy items like water bottles or climbing equipment in pockets located far from your back.

KELTY Lifetime Warranty

Kelty takes pride in its workmanship and undertakes to manufacture the best possible products. Kelty products are covered under warranty, to the original owner, for the lifetime of the product, against defects in materials or workmanship.

Since no Kelty product is indestructible, Kelty's warranty does not cover defects attributable to or resulting from normal wear and tear (ie: exhausted zippers), natural hazard damage (ie: weather, animals, ultraviolet [UV] damage on tents), abuse or alteration.

All products being returned require a Return Authorization number. Service under our warranty is available to the original purchaser by returning the product to any authorized Kelty dealer or by contacting our customer service department at 1-866-349-7225 (1-866-FIX-PACK) for a Return Authorization number.

If, after inspection, we determine that the product is defective, we will repair or replace it at our discretion, free of charge. If your Kelty product needs service or repair that is not covered under warranty, we will provide the necessary service at a reasonable charge.

This warranty gives you, the original purchaser, specific legal rights. You may also have other rights, which vary from state to state.